



Kendall mk2 Collection

Kendall 2F Floorstanding Loudspeaker



WELCOME!

Thank you for purchasing one of the best sounding loudspeakers ever produced. At KLH, we have been making high-quality components since 1957, and we take pride in making your music and movies the best experience possible.

FOR YOUR SAFETY

Important Safety Instructions!

1. READ these instructions.
2. KEEP these instructions.
3. HEED all warnings.
4. FOLLOW all instructions.
5. DO NOT use this apparatus near water.
6. CLEAN with dry cotton cloth. Do not use microfiber.
7. DO NOT block any ventilation openings. Install in accordance with the manufacturer's instructions.
8. Do not install near any heat sources such as radiators, heat registers, stoves, or other heat producing appliances
9. USE ONLY attachments/accessories specified by the manufacturer.
10. DO NOT expose to excess moisture or liquids, and do not place containers with liquids on top of speakers.



The exclamation point, within an equilateral triangle, is intended to alert the user to the presence of important operating and maintenance (servicing) instructions in the literature accompanying the product.



The lightning flash with arrowhead symbol within an equilateral triangle is intended to alert the user to the presence of uninsulated "dangerous voltage" within the product's enclosure that may be of sufficient magnitude to constitute a risk of electrical shock to persons.

EU COMPLIANCE INFORMATION:

Eligible to bear the CE mark, Conforms to European Union EMC Directive 2004/108/EC; European Union Restriction of Hazardous Substances Recast (RoHS2) Directive 2011/65/drivers.dEC; European Union WEEE Directive 2002/96/EC.

KLH and the KLH logo are registered trademarks of Kelley Global Brands Inc., registered in the U.S. and other countries.

WEEE NOTICE

Note: This mark applies only to countries within the European Union (EU) and Norway.



This appliance is labeled in accordance with European Directive 2002/96/EC concerning waste electrical and electronic equipment (WEEE). This label indicates that this product should not be disposed of with household waste. It should be deposited at an appropriate facility to enable recovery and recycling.

CONTENTS:

The spike feet assemblies contain two matching powder coated arms with two spikes and spike installation knobs each. There are also eight installation screws with Allen wrench.

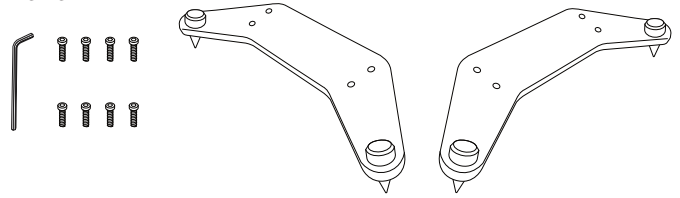

UNPACKING

Place the package on the floor with the box flaps up. Cut the tape with a utility knife to open the package. Fold the carton flaps back and carefully slide the speaker and packaging from the box, or turn the box over with flaps open and remove the box. Stand the speaker and packing upright, making sure the loudspeaker rubber feet are on the bottom, and remove the packing material.

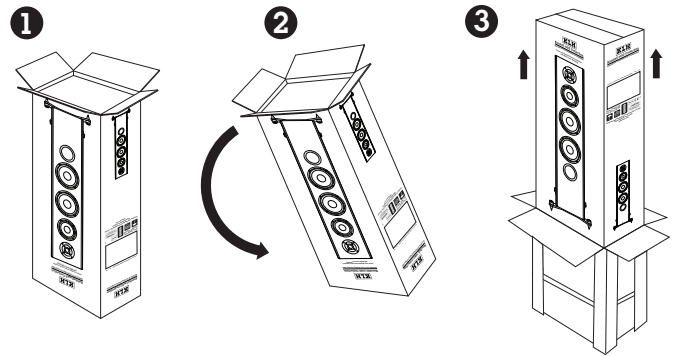

SPIKE AND RUBBER FEET

The Kendall 2F floorstanding speakers are equipped with rubber feet, and can be removed to install spiked feet assemblies. Spiked and rubber feet are to be used for bass decoupling (reducing bass transmission). To install metal spiked feet, you may place speaker on the floor on either side. DO NOT place speaker front on floor to avoid possible damage to drivers. To install spiked feet assembly, first remove rubber feet, and follow instructions below:

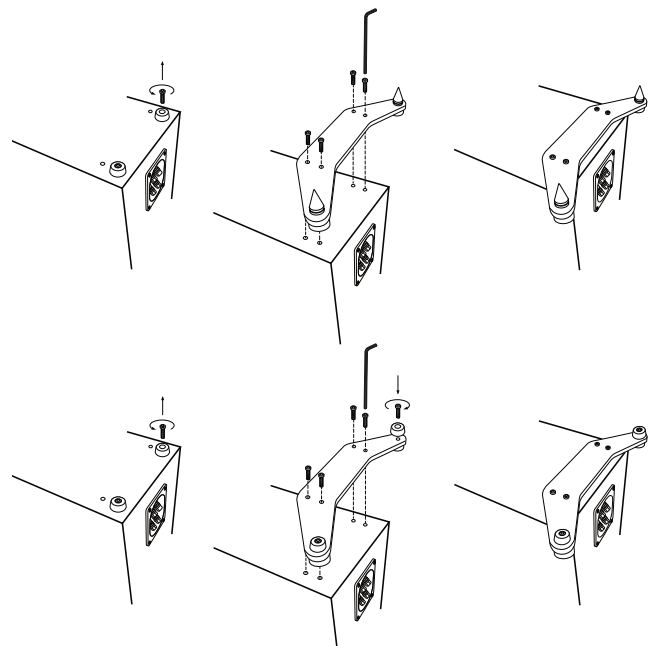

NOTE:

When moving loudspeakers take extra caution to place hands in a position that will not damage the drivers. This can best be done by placing one hand in the port at the back of the loudspeaker, and the other hand at either top corner.

ALWAYS KEEP HANDS AWAY FROM DRIVERS TO AVOID DAMAGE.

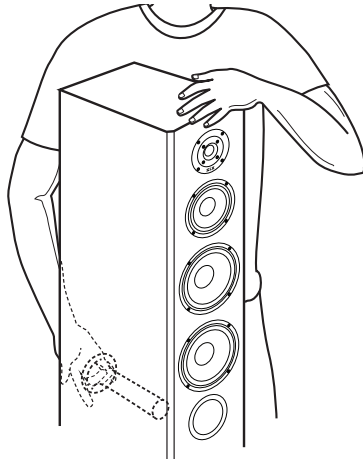

CONNECTING YOUR FLOORSTANDING LOUSPEAKERS

Both floorstanding loudspeakers have the same quality gold-plated binding posts that will accommodate stripped wire, spade connectors or banana plugs. Be sure to use quality speaker cables, up to 12 gauge (AWG). The lowest gauge possible is recommended. Before using banana plugs, be sure to remove the black and red inserts on the binding posts. The straps connecting the binding posts should remain in place for conventional wiring, but may be removed where bi-wiring is preferred. See the following diagrams in the AMPLIFICATION section for further instruction.

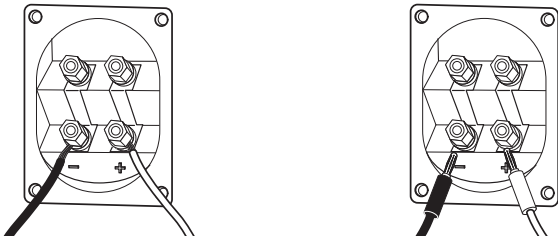

AMPLIFICATION

Conventional amplification involves a single stereo amplifier wired to a single set of binding posts with straps connecting the second set of posts as seen in diagram above. Simply attach the positive wire + to the red post, and the negative wire - to the black post.

BI-AMPLIFICATION

This connection method (see diagram below) uses two separate two channel amplifiers to power one set of speakers. One amplifier is attached to one set of binding posts, and another identical amplifier is attached to the other set of binding posts. This is referred to as bi-amplification.

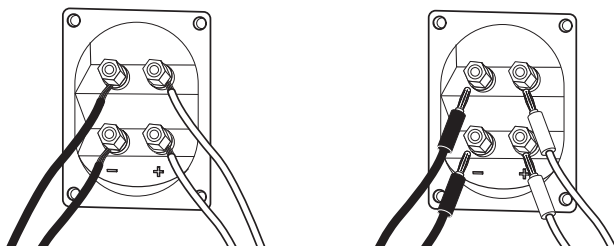

NOTE:

Binding post wrench is included



Be sure to remove the terminal straps before using the bi-amplification method. Connect positive + and negative - cables from the amplifier to the top terminals, and make sure the connection is tight. Connect the second set of cables (positive and negative) to the bottom terminals and tighten. Repeat these same steps using the second amplifier to connect to the second terminals.

ROOM POSITION

Placement of your floorstanding loudspeakers is a personal preference, but it is recommended that speakers be placed at least 6 feet apart whether they are being used for a stereo application, or as the main left and right channels for a home theater. For best imaging and separation, listening distance from the speakers should be about 1.25 times the distance the speakers are apart from each other.

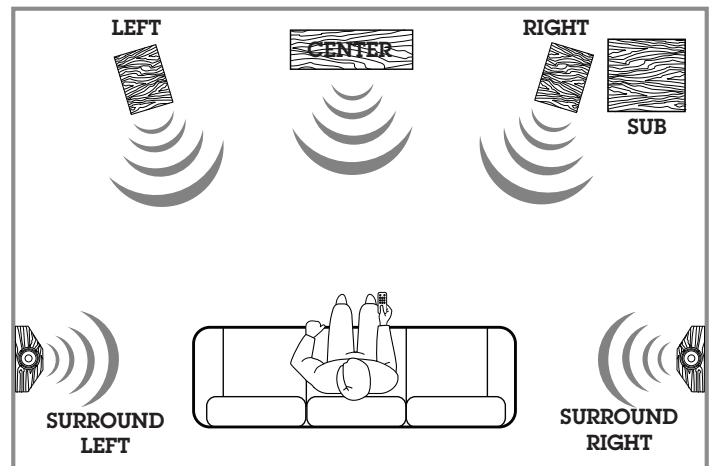

Example: If the distance between each speaker and the listening position is 10 feet, then the speakers should be 8 feet apart from one another. Be sure that loudspeakers are placed at least 12 inches away from any wall. Further adjustments can be made to optimize your listening experience.

WARRANTY

Our 10 year warranty begins from purchase date of the item. (Receipt Date) Warranty registration must be completed at KLHAUDIO.com/warranty. Registration of the product must be completed within 120 days of purchase for warranty validation. Original receipt of purchase must be retained for proof of purchase. For warranty or service issues, please contact authorized KLH dealer. The warranty covers any production and/or material defects of the product. This warranty is non-transferable.

The following is NOT COVERED by the warranty:

1. Accidents, misuse, poor maintenance, electrical overloads such as lightning or voltage.
2. Incorrect use of product.
3. Altered serial number.
4. Transportation costs for service call.
5. Purchase of KLH products from unauthorized reseller.

Replacement item cannot exceed the cost of the item under warranty. The supplier is responsible for only repair or replacement. KLH toll free number is 1-833-554-8326

SPECIFICATIONS

Kendall 2F Floorstanding Loudspeaker

Enclosure	3-Way, Bass-Reflex
Power handling	250 Watts.
Peak Power Handling	1,000 Watts
Frequency Response	36Hz-20kHz. +/-3dB
Impedance	8Ω.
Crossover Frequency	800Hz & 2,500Hz
Sensitivity in Room	91dB. 2.83V/1m
Sensitivity Anechoic	88dB. 2.83V/1m
Tweeter	Single 1" Titanium Dome Tweeter
Midrange	Single 5.25" Aluminum Cone Woofers
Woofers	Dual 6.5" Aluminum Cone Woofers
Finishes	English Walnut Wood Veneer or Black Oak Wood Veneer
Dimensions:	41" x 12.75" x 19" (H x W x D). With Outrigger Feet 41" x 8.75" x 17.5" (H x W x D). Without Outrigger Feet
Weight:	59 lbs.

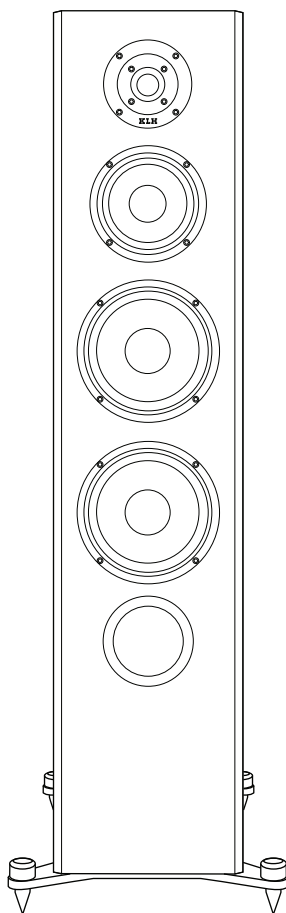

5520 Pebble Village Lane, Suite 100
Noblesville, IN 46062

klhaudio.com